

High performance specs

Building	
Construction completed	November, 2015
Floor area	12,500 sq.m (approx. 134,500 sq.ft.)
Server room space	3,500 sq.m (approx. 1,670 racks)
Office room space	430 sq.m (approx. 4,600 sq.ft.)
Main building	11 stories
Structure	Steel construction Seismic isolation structure
Floor load	1,500 kg/ sq.m (300 lb./ sq.ft.)
Raised floor	Floor height: 300mm
Loading Bay	One 4 t truck H = approx. 3.8 m
Freight elevator	W 3,250 mm x D 1,900 mm x H 2,800 mm Capacity: up to 5,000 kg
Parking space	Available
Ground level	O.P. +2.0 m *1
Building/ room access	Facility access: 24 hrs/ day Pre registration required via Web Entry System Speedy smart entry after photo ID confirmation, card key and rack keys are provided Operators are available 24 hrs/ day
Certification	ISO 9001 , ISO 14001, ISO 20000, ISO 22301, ISO 27001, PCI DSS, Privacy mark, SSAE 16/ ISAE 3402

*1 Osaka Peil

Facilities	
Power reception	Dual path system (from 2 electric power substations) Power reception voltage: 77,000 V Inspection: every 3 yrs (No need to interrupt system operation)
Generators	Gas turbine engines Operation without refueling: 48 hrs Startup tests conducted every 3 months
UPS	N+1 Parallel redundant configuration
Battery support time	5 mins
Power supply type	Single phase 100 V and 200 V Three phase 200 V HVDC(to be launched)
Air-conditioning	Water-cooling 24 hrs/ day N+1 configuration Cooling wall system Water-side economizer
Fire detection and suppression	Nitrogen gas fire suppression system Early Warning Smoke Detection System
Security	IC card + Biometric authentication Monitoring cameras Lockable rack with individual cylinder key
Network	Multi-carriers complied Directly connected to disaster resistant cable tunnel Nexcenter Connect™

Business Portal

Customer portal that enables customers to view their usage and status of major services provided by NTT Com and change various configurations on demand in a timely manner.

Main functions

- Entry request
- View information on facilities currently in use
- View building access logs
- View remote hands operation records
- Download information files



SD-Exchange

Connecting colocation and various cloud services globally. This solution optimizes the best system design in secured and high performance environment. You can also manage the network settings and changes from our portal flexibly.

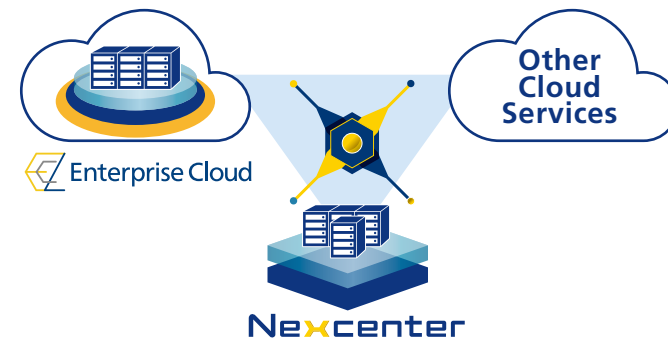

Extensive Service Menu

Service Categories		In addition to basic services, we offer a variety of optional services and customized services.	
Basic Services	19 inch cabinet racks	Compliant with EIA standards	
	Power supply	Stable power supply 24/ 7 with UPS and Generators	
	Security	Rack keys, Monitoring cameras	
	Room access management	Biometric authentication or IC card key required for room access	
	Air-conditioning	24 hours a day	
	Remote hands (Basic troubleshooting)	Visual checking, Power cycling, Reset button cycling	
Optional Services	Enhanced power supply	Choose from AC single phase 100 V 10 A, 20 A or 30 A/ AC single phase 200 V 15 A, 20 A or 30 A	
	Redundant power configuration	Choose redundant breaker or redundant power distribution unit	
	Stand-by power supply	Choose from AC single phase 100 V 20 A or 30 A/ AC single phase 200 V 15 A, 20 A or 30 A	
	Other power options	Earth, additional power outlets in racks, changes to power outlets	
	Rack options	Additional shelves and blank panels, change of rack keys, racks supplied by customers	
	Connectivity	Optic fiber cable; UTP cable; Metal cable	
	Remote hands	Customer's system construction, operation of equipment, trouble recovery and system management support in the data center	
Customized Services	Escort service		
	Private cage Other features as requested		
Managed Services	Server Operation Services	Customer's system monitoring and maintenance in the data center	
	Security Operation Services	The global integrated security service provides total security outsourcing	

NTT Communications Corporation

website <http://www.ntt.com>

The information contained herein is current as of Aug 2017
Details of services described are subject to change without notice. Please check at the time of application.
Names of companies and products are trademarks or registered trademarks of the respective companies.



OSAKA 5 DATA CENTER

Disaster-resistant Data Center in the heart of the business district

Nexcenter



Disaster Prevention Disaster-resistant Data Center

Anti-flooding measures

In the unlikely event that water were to reach the data center, equipment would continue to operate safely because the electric power equipment, communication facilities, server rooms and other important facilities are located on the second floor or above, over 7m above ground level.

Anti-earthquake measures

Piles are driven more than 50m into the hard foundation to support the building. The building's seismic-isolation devices, which lessen the impact of strong shaking by the earthquake, are installed on the post beneath the second floor. In addition, seismic dampers are installed to suppress the vertical shaking by epicentral earthquakes.

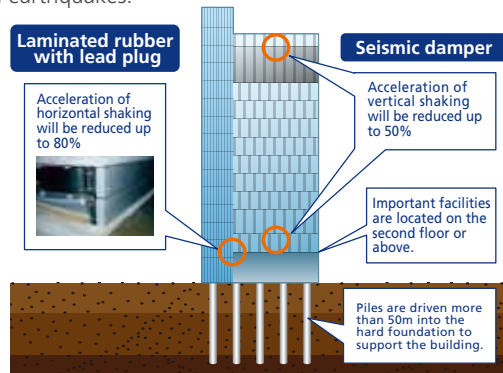

Electric power supply

Electricity is sourced from separate power substations for extra-highly reliable power supply.

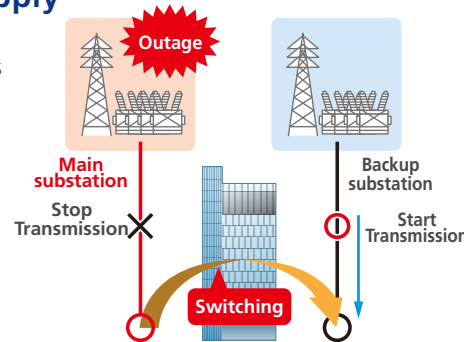

Network Ideal Network Environment

Network connection

The Osaka 5 Data Center is connected directly to the NTT Com's major data center in western Japan, which accommodates Internet exchange (IX), via optical fiber run through cable tunnels.

In addition to NTT Com's high-speed, high-volume Internet backbone and network services, including the Arcstar Universal One virtual private network, customers can use the data center to build seamless ICT environments combining cloud services with data centers worldwide.

Stable Communications

Communications routes are laid from four directions, include connected directly to secure earthquake-proof cable tunnel, with no damage from past major earthquakes.

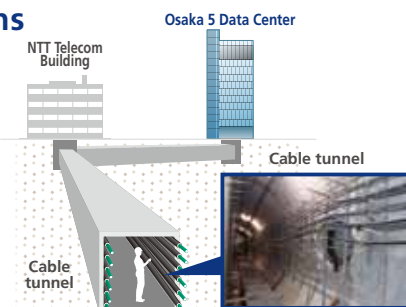

3 Seismic damper



4 Rooftop heliport

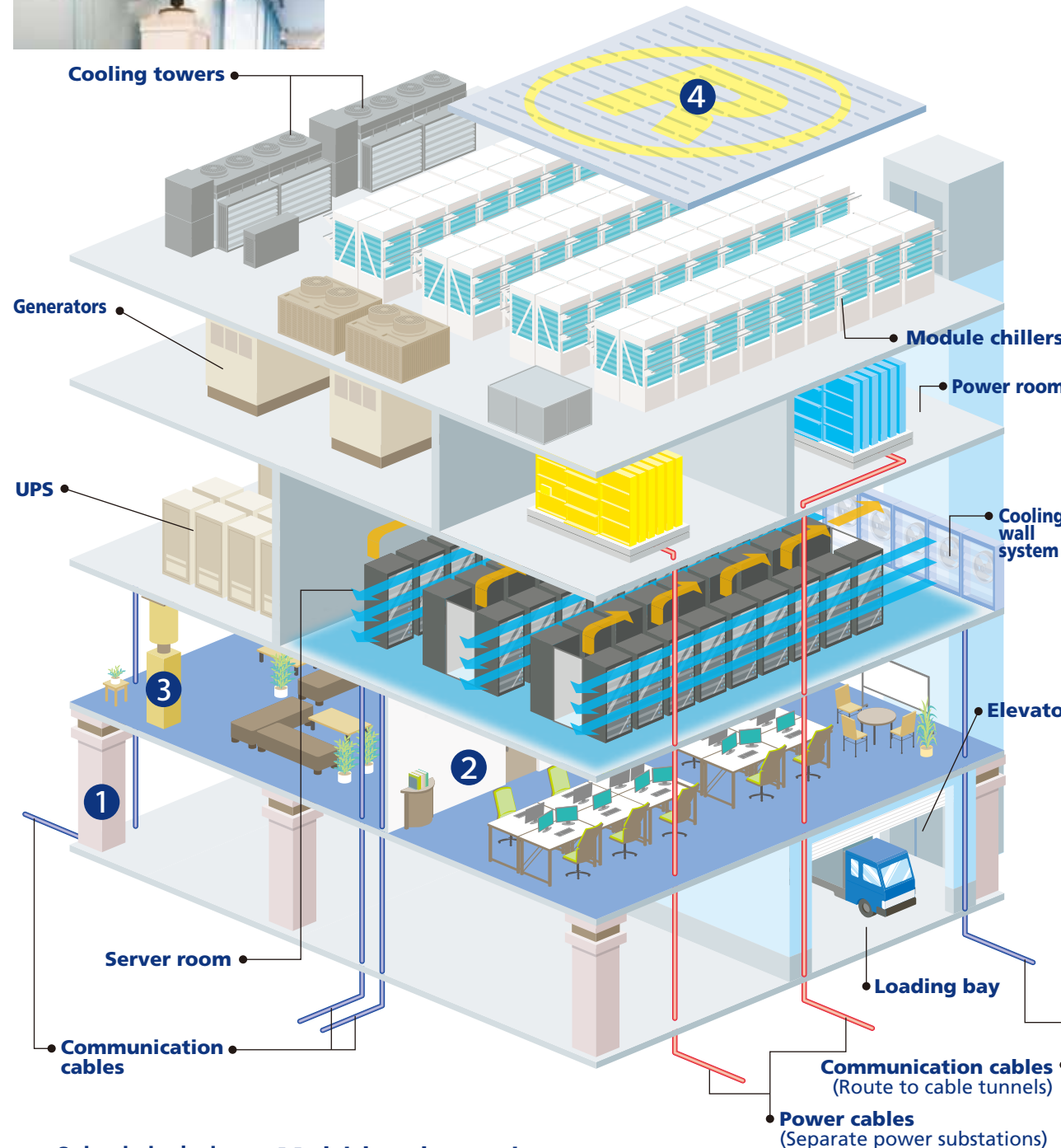

1 Seismic-isolation device



Multi-level security

- Prior registration using a Web entry system
- Personal authentication using a finger vein authentication device



©Entrance Lobby

©Monitoring camera

©Security gate

©Finger vein authentication device

Location

Convenient location

Located in Osaka metropolitan area, and accessible from multiple stations to the building.

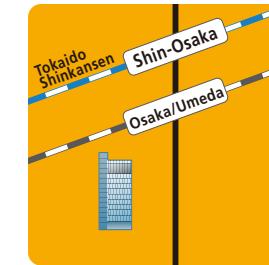

Shin-Osaka Sta.
20 min by train
Nearest Sta.
4 min on foot

Green ICT

Advanced energy saving technologies

Cooling wall system

Compact and high-efficient Water-cooling system, in addition NTT Com has pioneered the adoption of efficient cooling wall which blows cold air in the server room.

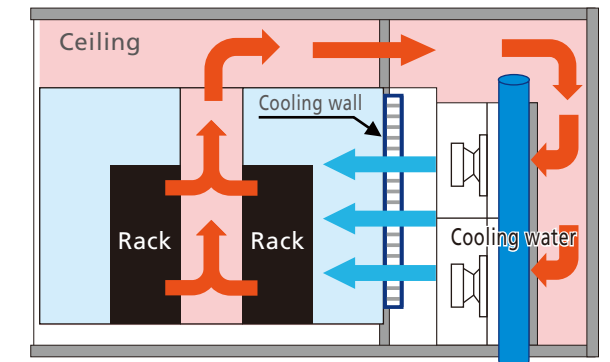

Water-side economizer

By using cold outdoor air, power consumption of air conditioning will be reduced.

2 Other facilities

- Office space is available for customer's system monitoring, maintenance center or BCP office.
- Comfortable lounge for your break and meeting
- Designated staging area is available for setting your equipment to your racks



©Rental office space



©Customer Lounge

Nexcenter

Nexcenter™ is NTT Communications' brand name for the next generation data center services, offering world-class quality, outstanding cost efficiency and full-support ICT menu.